

**Best lifting performance**

- ⇒ Optimised load rating
- ⇒ High maximum reach capacity

Best Precision and user comfort

- ⇒ Full hydrostatic transmission for more comfort and productivity
- ⇒ Smooth boom design with everything inside for best side visibility
- ⇒ Dangerous movements cut out switch

Compact and Strong

- ⇒ 5 m Length
- ⇒ Stabilizers lowering on a 2,26 m width



Placing height : 10 m

Maximum lift capacity :
3200 kg
Haulotte 
GROUP

More than lifting



HTL 3210

Placing height : 10 m
Maximum lift capacity : 3200 kg

TELEHANDLER

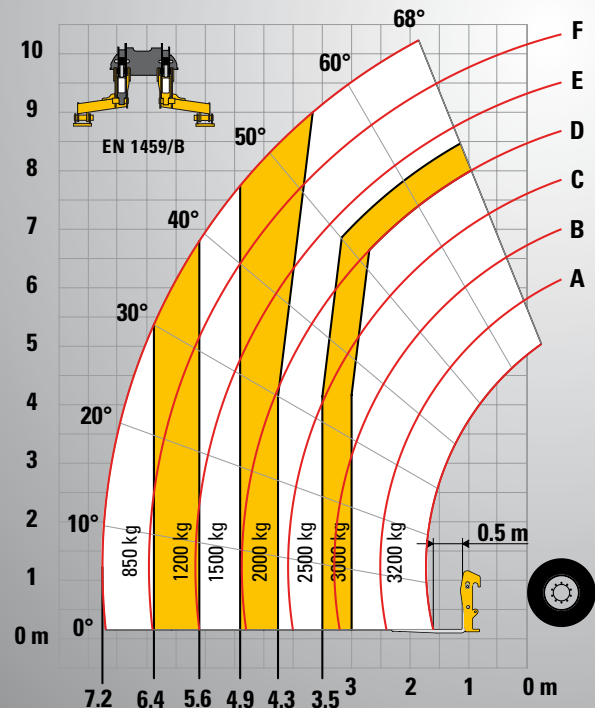
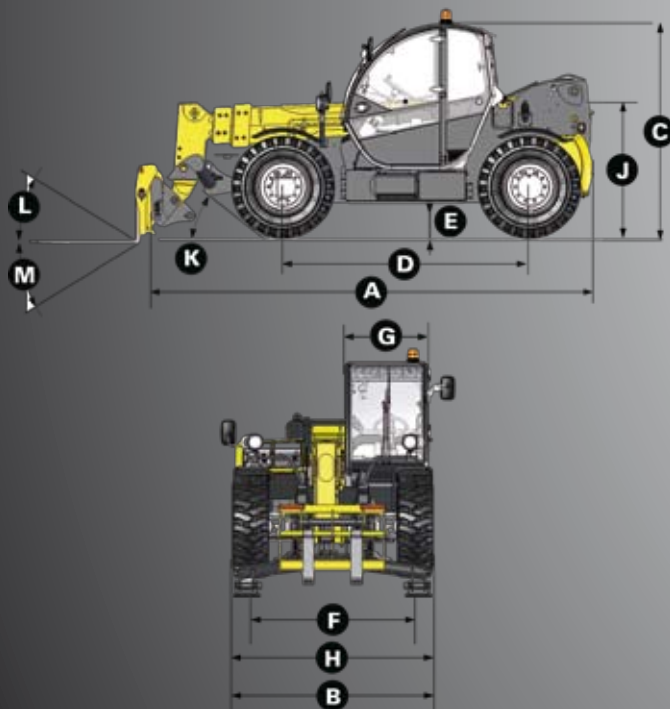

PERFORMANCES

Maximum lift capacity	3200 kg
Lift capacity to full height	2500 kg
Lift capacity at full reach	850 kg
Maximum fork height	10 m
Reach at maximum fork height	2.2 m
Maximum forward reach	7.2 m

DIMENSIONS

A - Length	4.96 m
B - Width	2.26 m
C - Height	2.38 m
D - Wheelbase	2.78 m
E - Ground clearance	42 cm
F - Track width	1.88 m
G - Cab width	0.96 m
H - Overall width - stabilizers down	2.26 m
J - Height to high boom pivot	1.6 m
K - Approach angle	30 °
L - Upper rotation of forks	18 °
M - Lower rotation of forks	104 °
Turning radius (outside wheels)	3.7 m
Weight with forks	7850 kg
Tyres type	405/70 - 20

ENGINE

Engine model	Perkins 1104
Engine Capacity	4400 cm ³
Engine power output	62 kW / 84 CV
Engine torque	354 Nm
Transmission type	Hydrostatic
Fuel tank	120 l
Engine oil	103 l

STANDARD EQUIPMENT

- Hydrostatic transmission with variable capacity pump and engine
- 4 wheel drive and steer
- Fuel filter with water separator
- Gear equipment pump
- Electrically hydraulic controls
- Proportional controls for movement of boom/telescopic arm/excavation and accessories
- Safety valves on hydraulic jacks
- Auxilliary hydraulic ports
- Overload/dangerous movements cut out switch
- Stabilizers lowering on a 2,26 m width
- ROPS/FOPS cabin with heating and ventilation

OPTIONS AND ACCESSORIES

- Cold Weather Package
- Biodegradable oil
- Cold environment oil
- Hot environment oil
- Air conditioning
- Working lights
- 4-in-1 bucket and standards
- Jib attachment and winch



Haulotte
GROUP