



### Adaptability and Performance

- Optimised load rating
- Hydraulic control for standard accessories
- Tilt corrector as standard

### Power and precision

- Standard hydrostatic transmission
- Simultaneous and proportional controls of all 4 movements of the boom with flow sharing

### Safety and reliability

- Standard rear axle locking
- Dangerous movements cut out switch



Placing height:  
13,60 m



Maximum lift capacity:  
3600 kg

**Haulotte**   
GROUP

Experience in innovation



# HTL 3614

Placing height: 13,60 m  
Maximum lift capacity: 3600 kg

## TELEHANDLER

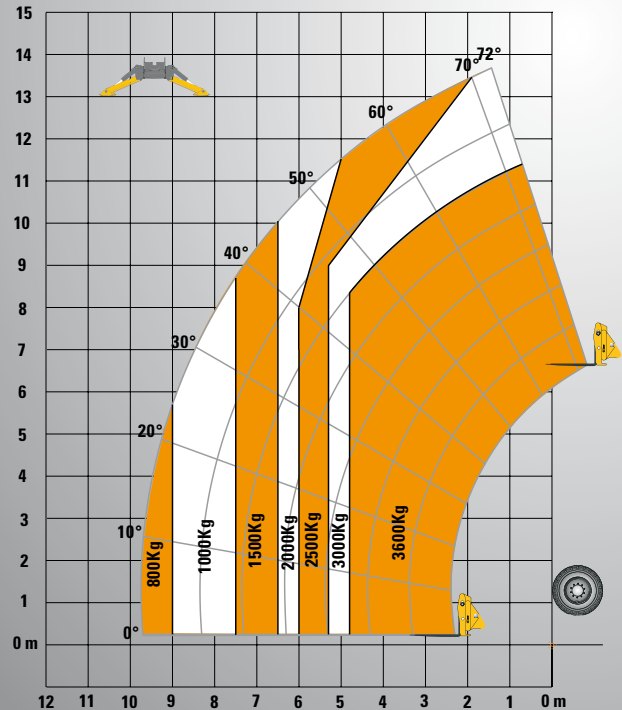
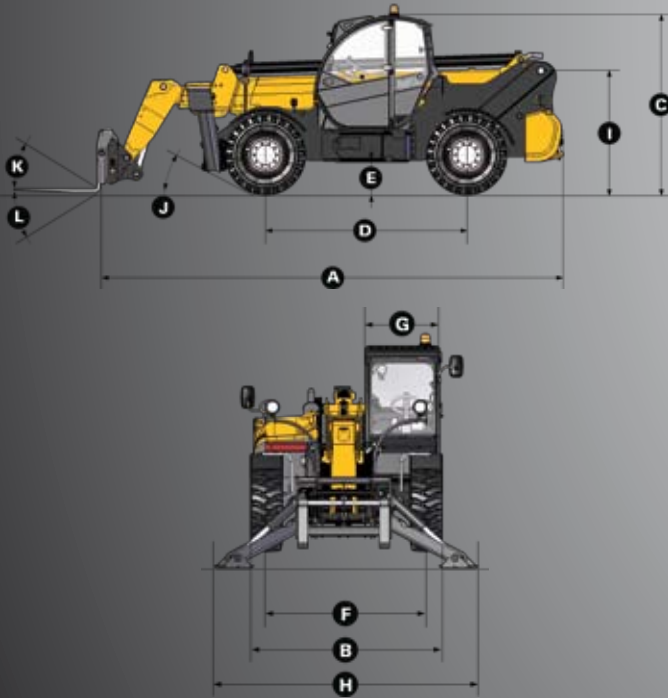

### PERFORMANCES

Maximum lift capacity	3600 kg
Lift capacity to full height	3000 kg
Lift capacity at full reach	800 kg
Maximum fork height	13.6 m
Reach at maximum fork height	1.5 m
Maximum forward reach	9.8 m



### DIMENSIONS

A - Length	6.43 m
B - Width	2.43 m
C - Height	2.6 m
D - Wheelbase	2.89 m
E - Ground clearance	50 cm
F - Track width	2 m
G - Cab width	0.96 m
H - Overall width - stabilizers down	3.34 m
I - Height to high boom pivot	1.76 m
J - Approach angle	29 °
K - Upper rotation of forks	18 °
L - Lower rotation of forks	104 °
Weight with forks	10710 kg
Tyres type	405/70 - 24



### ENGINE

Engine model	Deutz Turbo TCD2012
Engine Capacity	4000 cm <sup>3</sup>
Engine power output	68 kW / 93 CV
Engine torque	360 Nm
Transmission type	Hydrostatic
Fuel tank	133 l
Engine oil	110 l

### STANDARD EQUIPMENT

- Hydrostatic transmission with variable capacity pump and engine
- 4 wheel drive and steer
- Fuel filter with water separator
- Gear equipment pump
- Flow-Sharing electrically controlled controls
- Proportional controls for movement of boom/telescopic arm/excavation and accessories
- Safety valves on hydraulic jacks
- Possibility to combine mast/telescopic boom/excavation and accessories movements
- Auxilliary hydraulic ports
- Overload/dangerous movements cut out switch
- Tilt corrector: +/- 10 °
- Long stabilizers and large footplates for greater stability
- ROPS/FOPS cabin with heating and ventilation
- Rear axle locking

### OPTIONS AND ACCESSORIES

- Cold environment kit
- Biodegradable oil
- Cold environment oil
- Hot environment oil
- Air conditioning
- Working lights
- 4-in-1 bucket and standards
- Jib attachment and winch

**Haulotte**   
GROUP