

ALFA M evo

Manual movement and lifting for maximum comfort and simplicity when handling loads that are not particularly heavy.



ALFA SMALL 12V evo

Version with manual movement and electro-hydraulic elevation for quick lifting operations without operator's physical effort. Single-stage lifting mast for lift heights between 800 and 1600 mm.



ALFA 12V evo

Semi-electric version with two-stage mast for lift heights up to 3.5 meters.

Features in detail: _____



ADJUSTABLE FORKS:

Forks can be manually adjusted in the fork holder plate; a simple operation that allows using the same truck for loads that have different overall dimensions.



DRIVING HANDLES:

Side handles to assure easy maneuvering and positioning of the truck with manual movements.



MANUAL LIFTING (ALFA M evo):

Quick lift hand pump with lowering control installed in the same pump to facilitate a quick execution of every operation.



ELECTRO-HYDRAULIC LIFTING (12V versions):

Lifting and lowering control switches are installed in a protective casing. An Emergency Stop switch cuts the power supply.



ALFA M evo

model		55/08	105/08	25/16	55/16	105/16
Q	Kg	500	1000	250	500	1000
C	mm	600	600	400	400	400
I	mm	1150	1150	800	800	800
L	mm	1730	1730	1210	1380	1380
X	mm	400	400	130	200	200
Y	mm	1270	1270	1015	1120	1120
L2	mm	580	580	405	580	580
M	mm	200/800	240/800	200/800	200/800	240/800
N	mm	100	120	100	100	120
h1	mm	1230	1230	1990	1990	1990
h2	mm	800	800	1600	1600	1600
h3	mm	800	800	1600	1600	1600
h4	mm	1240	1240	1990	2000	2000
B	mm	800	800	800	800	800
E	mm	520	530	540	520	530
F	mm	405	350	415	405	350
S	mm	50	55	42	50	55
WA	mm	1320	1320	1135	1135	1135

STANDARD EQUIPMENT

- High free lift (simplex mast) • Lifting by fast manual pump (without load) • Descent by lever • Adjustable forks length 800 mm (1150 mm for 800 mm lifting height) • Parking Brake • Polyurethane single roller • Polyamide wheels with polyurethane covering • Safety components • Manual Traction

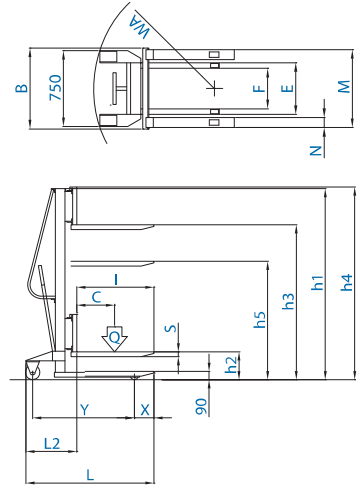

ALFA SMALL 12V evo

model		55/08	105/08	55/16	105/16
Q	Kg	500	1000	500	1000
C	mm	600	600	400	400
I	mm	1150	1150	800	800
L	mm	1730	1730	1380	1380
X	mm	400	400	200	200
Y	mm	1270	1270	1120	1120
L2	mm	580	580	580	580
M	mm	200/800	240/800	200/800	240/800
N	mm	100	120	100	120
h1	mm	1230	1230	1990	1990
h2	mm	800	800	1600	1600
h3	mm	800	800	1600	1600
h4	mm	1240	1240	2000	2000
B	mm	800	800	800	800
E	mm	520	520	520	530
F	mm	405	405	405	350
S	mm	50	55	50	55
WA	mm	1320	1320	1135	1135

STANDARD EQUIPMENT

- High free lift (simplex mast) • Built-in electronic battery charger 12V 10A with microprocessor • Forks control by push-buttons • Adjustable forks length 800 mm (1150 mm for 800 mm lifting height) • Parking Brake • Polyurethane single roller • Polyamide wheels with polyurethane covering • Safety components • Manual Traction • Battery 12V 80 AH

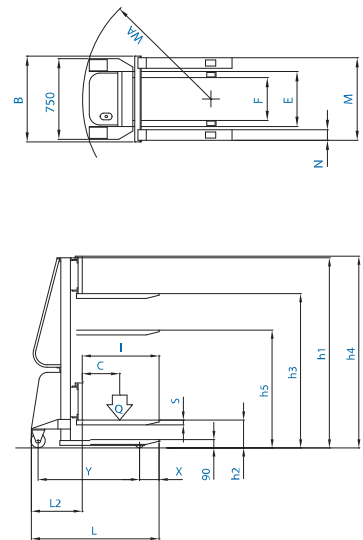

ALFA 12V evo

model		55/25	105/25	55/30	105/30	55/35	105/35
Q	Kg	500	1000	500	1000	500	1000
C	mm	400	400	400	400	400	400
I	mm	800	800	800	800	800	800
L	mm	1390	1410	1390	1410	1390	1410
X	mm	200	200	200	200	200	200
Y	mm	1135	1155	1135	1155	1135	1155
L2	mm	585	605	585	605	585	605
M	mm	240/800	240/800	240/800	240/800	240/800	240/800
N	mm	120	120	120	120	120	120
h1	mm	1750	1750	1990	1990	2250	2250
h2	mm	200	200	200	200	/	/
h3	mm	2500	2500	3000	3000	3500	3500
h4	mm	2920	2920	3420	3420	3920	3920
B	mm	800	800	800	800	800	800
E	mm	525	525	525	525	525	525
F	mm	355	355	355	355	355	355
S	mm	50	55	50	55	50	55
WA	mm	1200	1220	1200	1220	1200	1220

STANDARD EQUIPMENT

- Free lift 200 mm (excluded lifting height mm. 3500) • Built-in electronic battery charger 12V 15A with microprocessor • Forks control by push-buttons • Adjustable forks length 800 mm • Electric end stroke • Parking Brake • Polyurethane single roller • Polyamide wheels with polyurethane covering • Safety components • Manual Traction • Battery 12V 155 AH

