

MAX AC-evo

Maximum Power for maximum performance

Capacity (kg): 1300 - 1600 - 2000 Lifting Height (mm): 1600, 2500, 3000, 3500

MAX AC-evo

Designed for maximum performance and safety for extreme loads in the most demanding applications, the MAX has extra heavy-duty masts, forks, frames and legs. Load capacities to 2000 kg and lift heights to 3.5 meters.



Masts made with extruded metal

Masts with heavy-duty special steel sections offer strength and stability in the most demanding applications.

AC technology

- + Performance
- + Driving control
- Service Costs

FULLY POWERED STACKERS

Feature in details: _____



DOUBLE SIDE PISTON:

Maximum performance, stability and safety result from two powerful side-mounted pistons.



NEW "DR EVO" DRIVE STEERING:

Includes LED battery charge indicator, "turtle" switch for variable speed control, precision proportional lifting / lowering control and safety reversing (crushproof) switch.



FREEDOM FROM DOWNTIME:

Powered by 24V industrial batteries with capacities to 270 Ah. A battery charger is built-in to the stacker control housing and includes a 220VAC power cord.



TRACTION AND STABILITY:

Structure with 5 contact points and shock-absorber system for perfect grip by the driving wheel in case of floor irregularities. Includes motor-wheel with SEM technology and energy recovery braking system.



Full Visibility

The two lifting pistons are installed on the side to give the operator full visibility in front of the truck during handling and storing operations.



MAX AC-evo [1600 mm - 2500 mm]

model		130/16	160/16	200/16	130/25	160/25	200/25
Q	Kg	1300	1600	2000	1300	1600	2000
C	mm	600	600	600	600	600	600
I	mm	1150	1150	1150	1150	1150	1150
L	mm	1920	1920	1940	1940	1940	1960
X	mm	380	380	380	380	380	380
X2	mm	175	175	175	175	175	175
Y	mm	1365	1365	1385	1385	1385	1405
L2	mm	760	760	780	780	780	800
M	mm	530	530	550	530	530	550
N	mm	160	160	180	160	160	180
h1	mm	1990	1990	1990	1740	1740	1740
h2	mm	1450	1450	1450	200	200	200
h3	mm	1600	1600	1600	2500	2500	2500
h4	mm	2120	2120	2120	3020	3020	3020
B	mm	840	840	1000	840	840	1000
WA	mm	1550	1550	1550	1570	1570	1570

STANDARD EQUIPMENT

• AC three-phase technology traction motors • Free lift 200 mm • Built-in electronic battery charger 24V 30A with microprocessor • Forks control by push-buttons • Fixed forks length mm. 1150 • Electric end stroke • Parking Brake • Braking in release contra flow • Shock absorber on driving-wheel • Side wheels with extra-heavy castors • High-frequency electronic plant 24V with microprocessor fault research • High visibility extruded mast with lateral contrast bearings • Double lateral chromed pistons • Exhausted battery warning-indicator • DR-EVO Steering • Automatic speed reduction • Safety components • Traction Battery 24V from 160 to 270 Ah

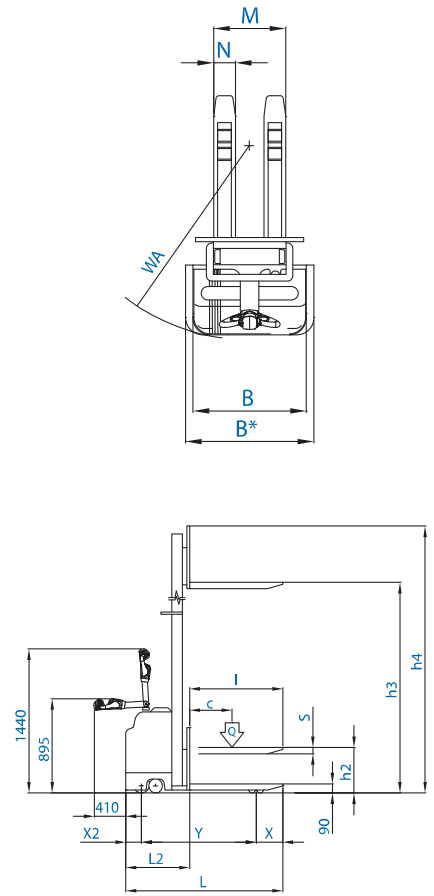

MAX AC-evo [3000 mm - 3500 mm]

model		130/30	160/30	200/30	130/35	160/35	200/35
Q	Kg	1300	1600	2000	1300	1600	2000
C	mm	600	600	600	600	600	600
I	mm	1150	1150	1150	1150	1150	1150
L	mm	1940	1940	1960	1940	1940	1960
X	mm	380	380	380	380	380	380
X2	mm	175	175	175	175	175	175
Y	mm	1385	1385	1405	1385	1385	1405
L2	mm	780	780	800	780	780	800
M	mm	530	530	550	530	530	550
N	mm	160	160	180	160	160	180
h1	mm	1990	1990	1990	2240	2240	2240
h2	mm	200	200	200	/	/	/
h3	mm	3000	3000	3000	3500	3500	3500
h4	mm	3520	3520	3520	4020	4020	4020
B	mm	840	840	1000	1000	1000	1000
WA	mm	1570	1570	1570	1570	1570	1570

STANDARD EQUIPMENT

• AC three-phase technology traction motors • Free lift 200 mm (excluded lifting height mm. 3500) • Built-in electronic battery charger 24V 30A with microprocessor • Forks control by push-buttons • Fixed forks length mm. 1150 • Electric end stroke • Parking Brake • Braking in release contra flow • Shock absorber on driving-wheel • Side wheels with extra-heavy castors • High-frequency electronic plant 24V with microprocessor fault research • High visibility extruded mast with lateral contrast bearings • Double lateral chromed pistons • Exhausted battery warning-indicator • DR-EVO Steering • Automatic speed reduction • Safety components • Traction Battery 24V from 160 to 270 Ah

